

Internal DC grids for wind farms – design and control issues

Ola Carlson

Lena Max

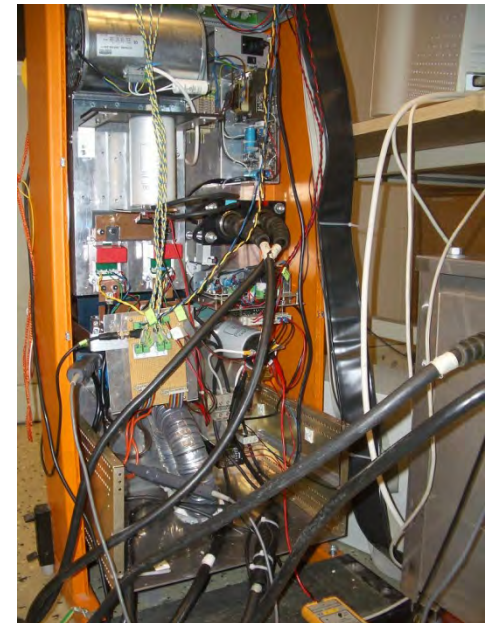

The internal DC grid

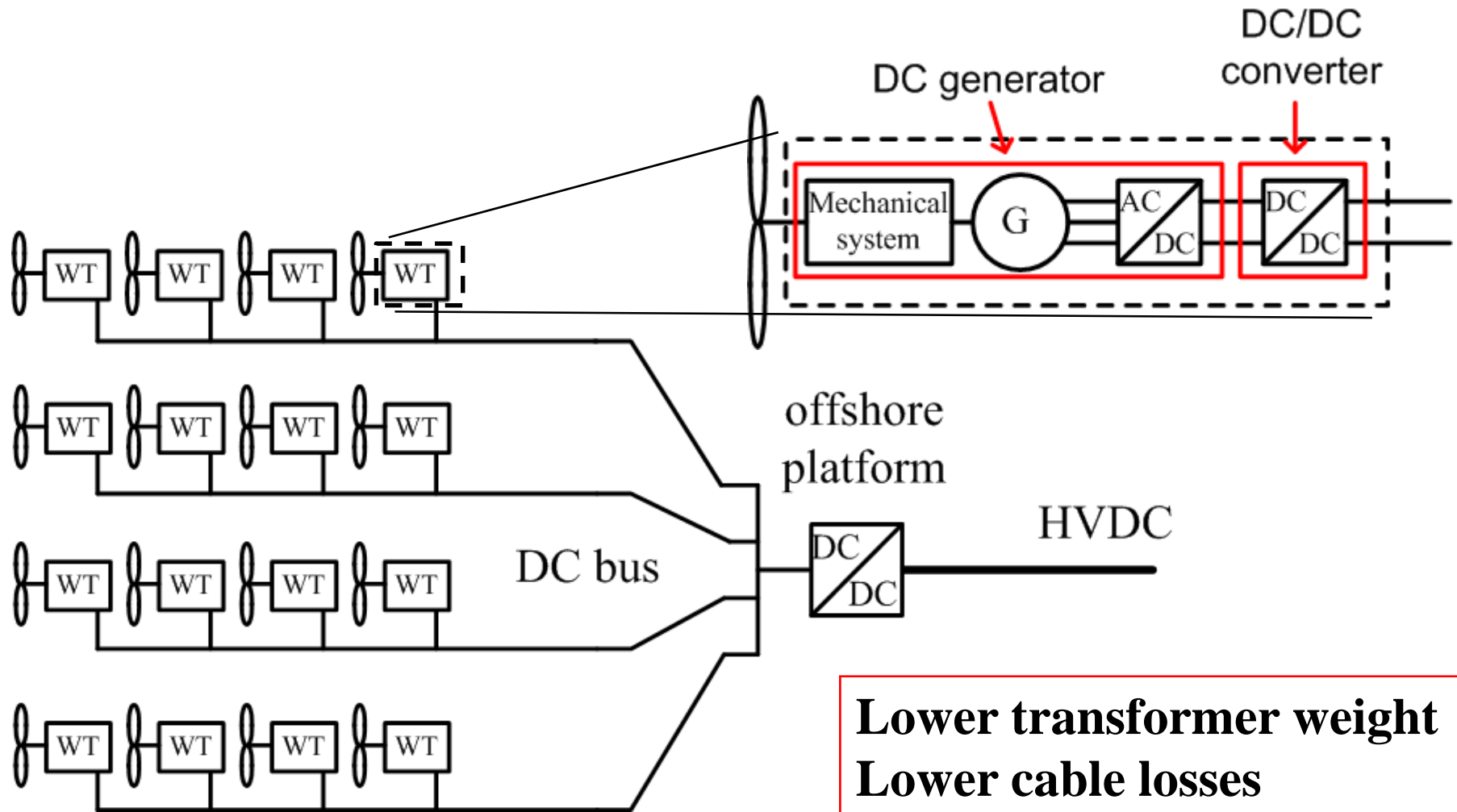

Electrical configuration in the turbine

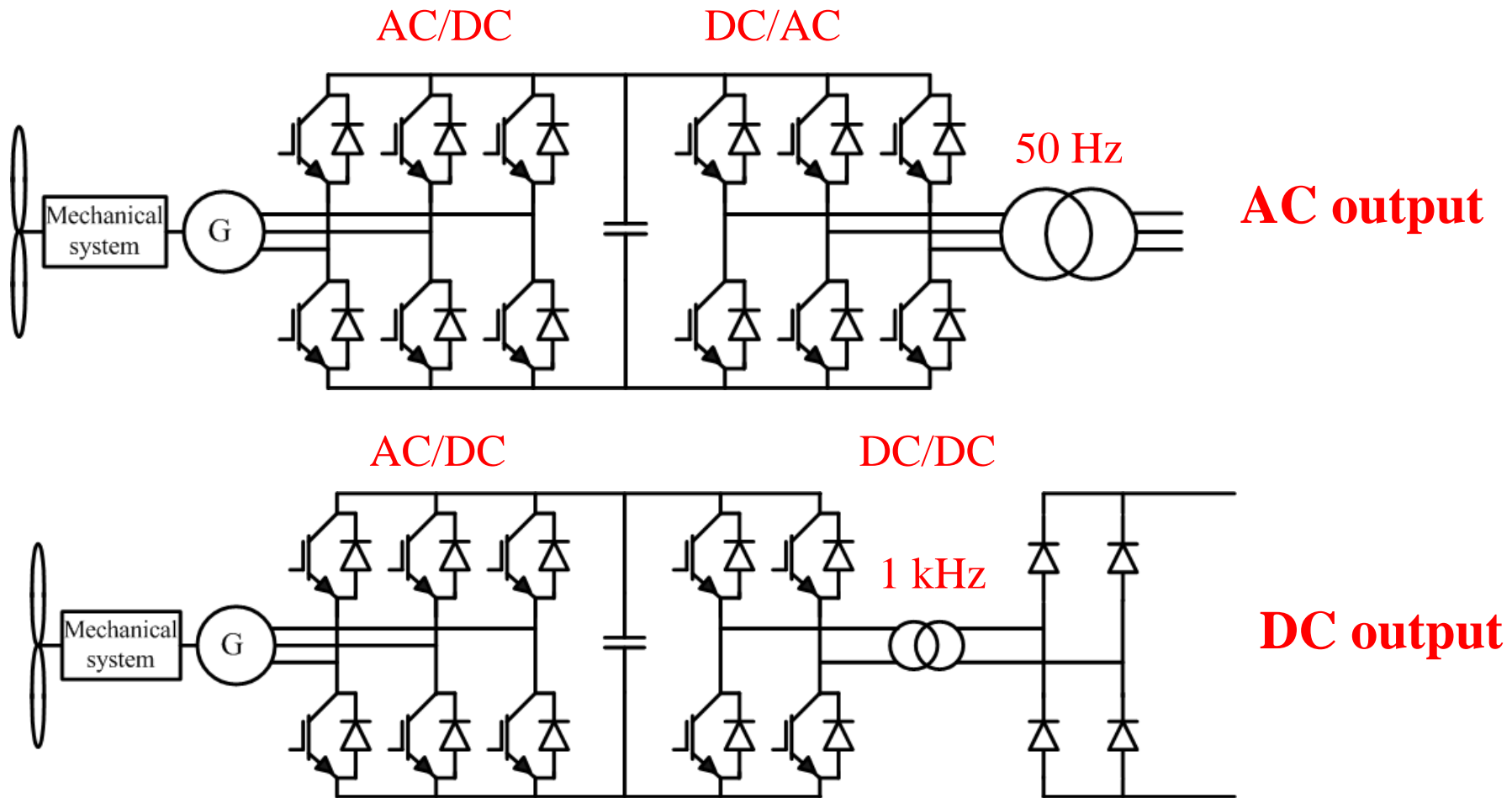

Design of the medium frequency converter

Choice of switching frequency

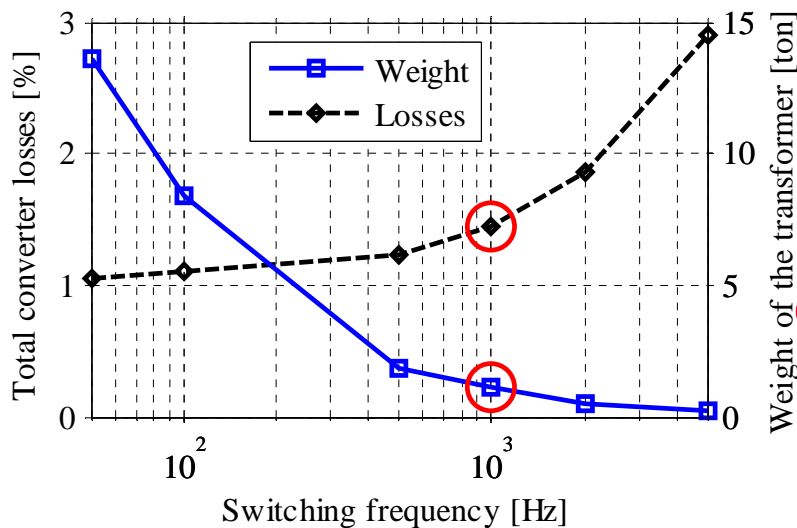

90% weight reduction from
13 ton to 1.3 ton

Chosen design: 1 kHz switching frequency using the amorphous metal alloy transformer core material.

Choice of transformer core material

Core material	Sat. flux	Loss density	Freq. range
Laminated steel	1.7 T	High	- 2 kHz
Amorphous metal alloy	1.5 T	Medium	- 10 kHz
Ferrite	0.3 T	Low	10 kHz -

Layout for the wind farm

The layout of the Lillgrund wind farm is used with 48 2.3 MW turbines

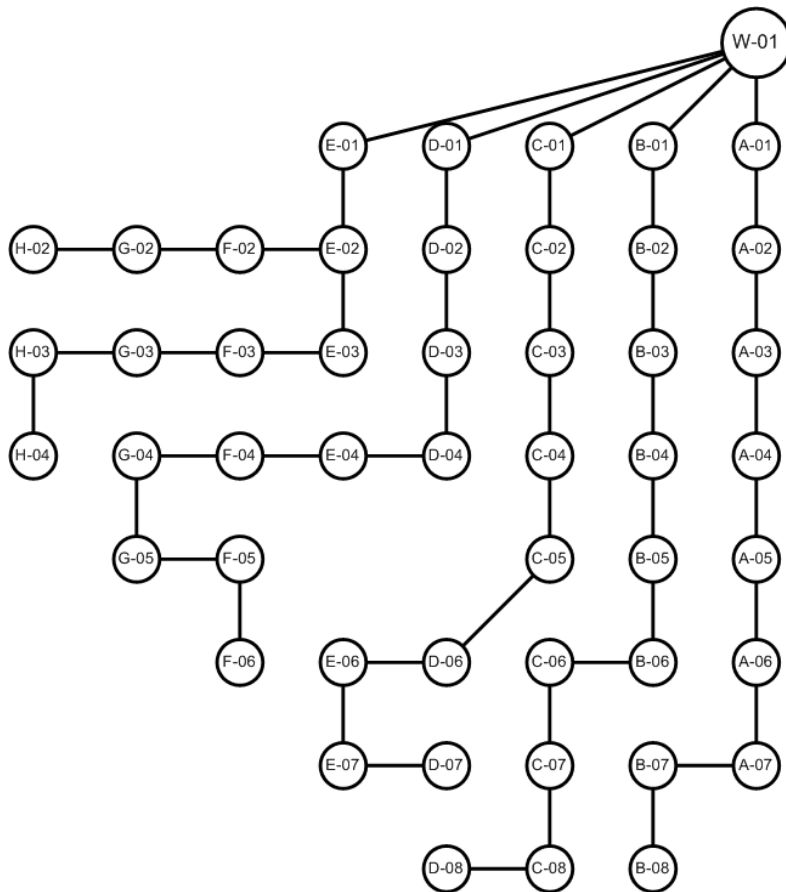

Operation of the DC based wind farm

Operation during a sudden step in the wind speed from 5 m/s to 10 m/s

The demands on the wind turbine is dependent on the dynamics of the average wind speed for the rotor disk.

Slow dynamics

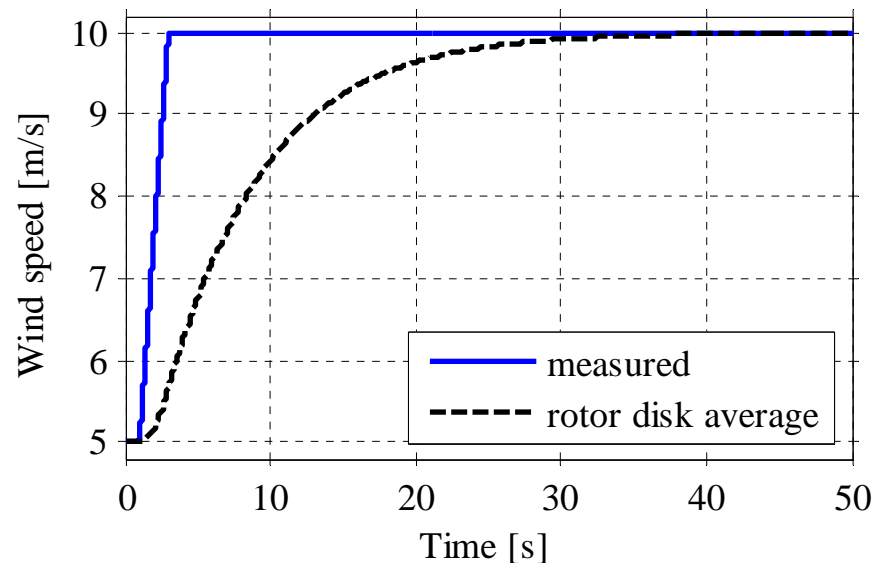

Fast dynamics

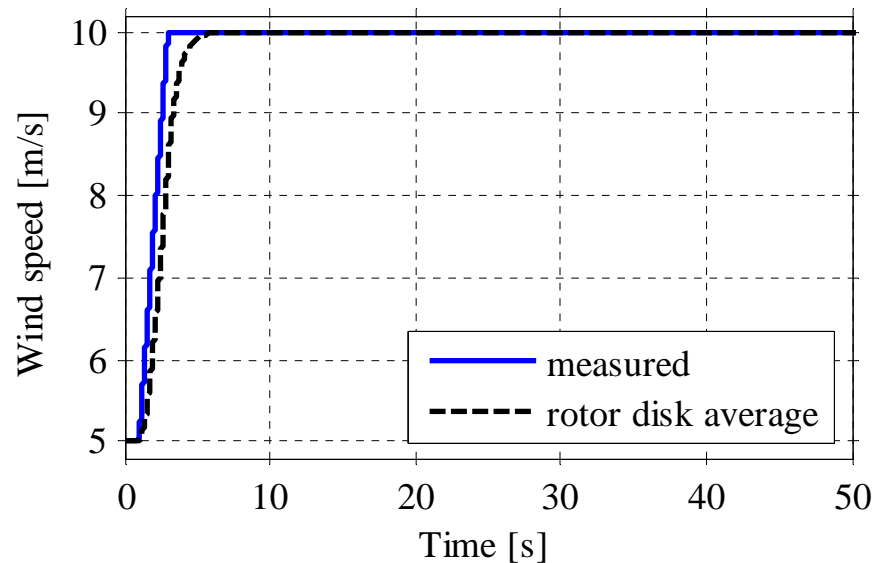

Operation of the DC based wind farm

Operation during a sudden step in the wind speed from 5 m/s to 10 m/s

Slow dynamics

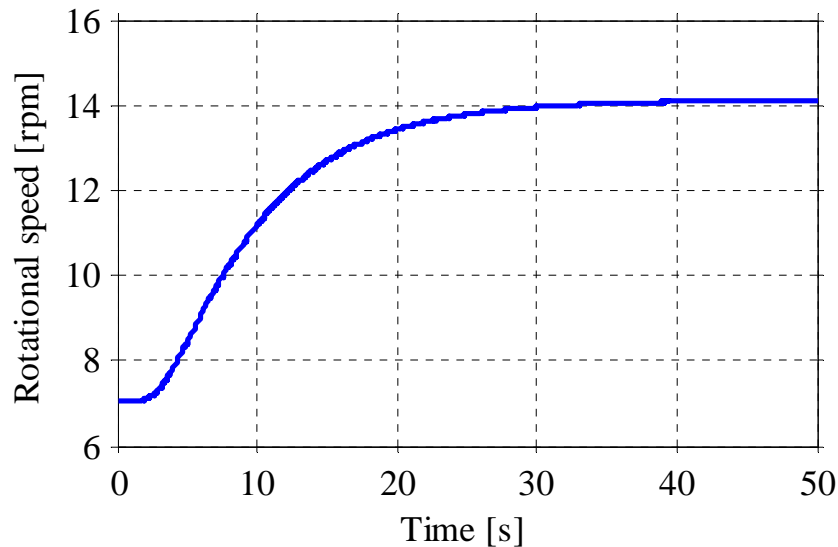

Fast dynamics

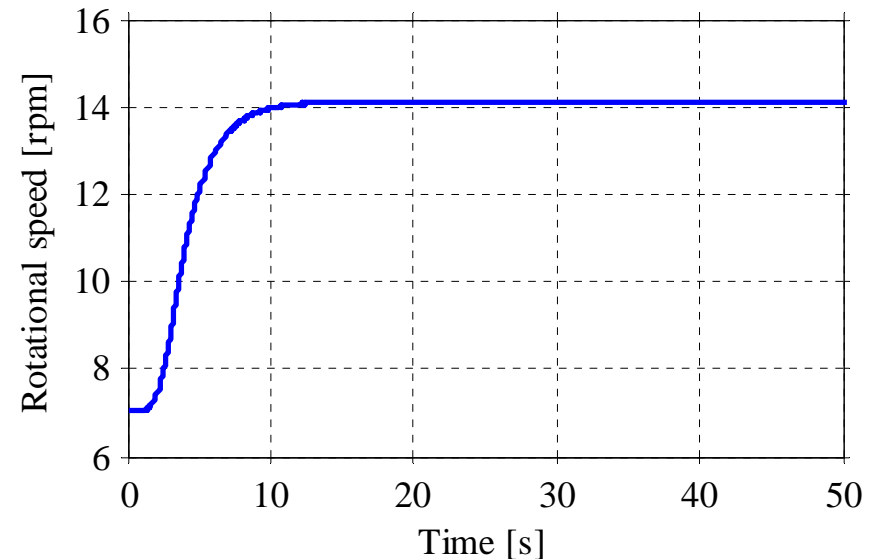

Delay of 50 s between the wind steps for the different rows of turbines.

Operation of the DC based wind farm

Operation during a sudden step in the wind speed from 5 m/s to 10 m/s

Electrical output power for the fast dynamics.

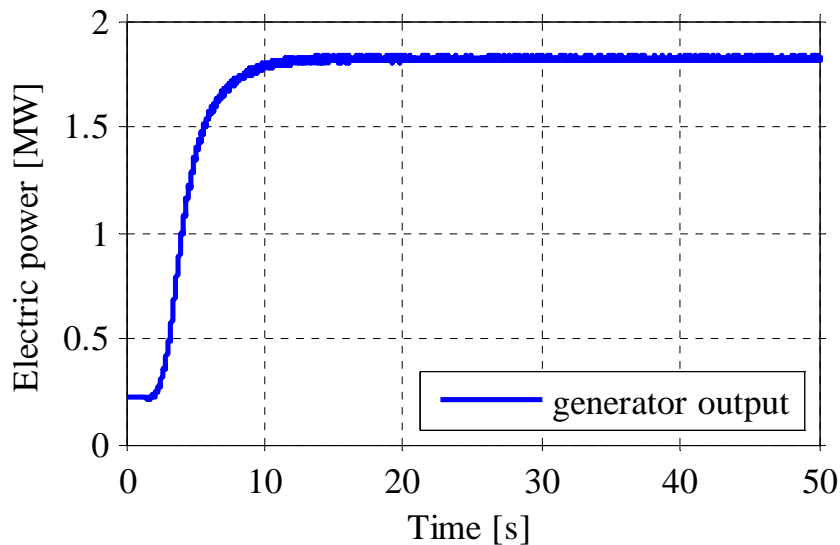

Electrical power from the generator

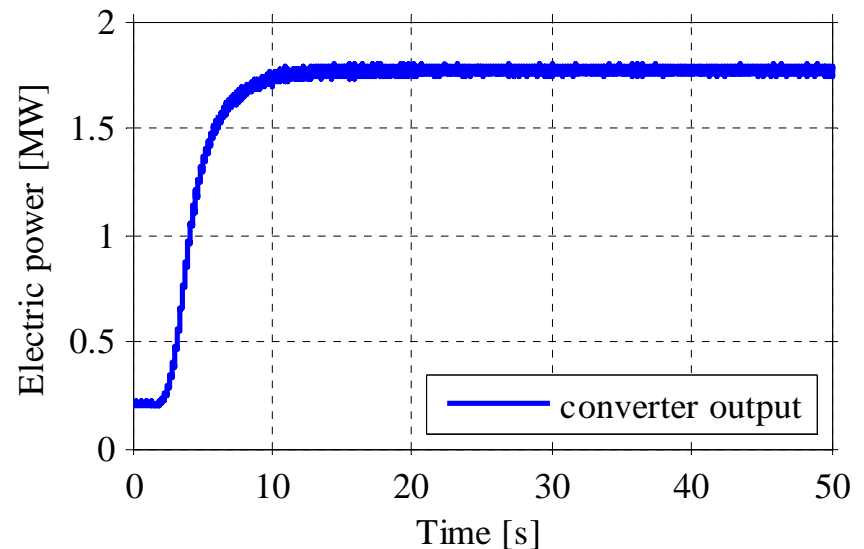

Electrical power from the wind turbine DC/DC converter

Operation of the DC based wind farm

Operation during a sudden step in the wind speed from 5 m/s to 10 m/s

Behavior of the internal grid for the fast dynamics.

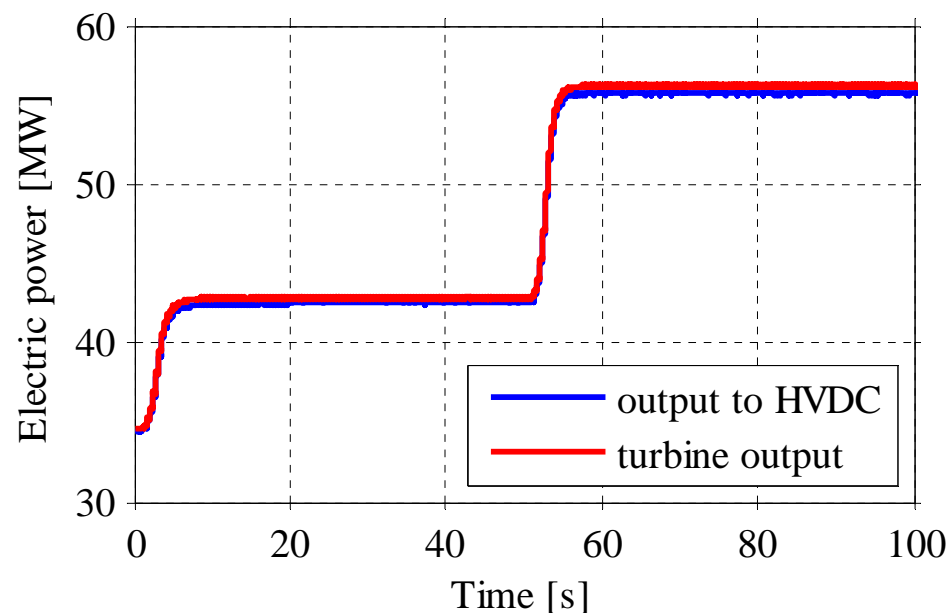
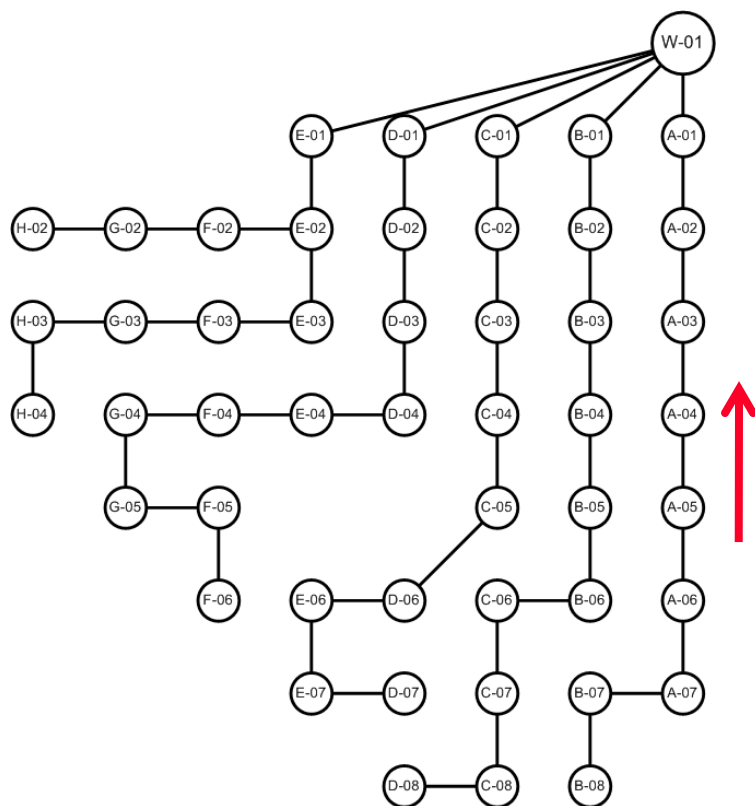

Conclusions

- The demands for control bandwidth for a wind turbine depends on the average wind speed seen from the rotor disk.
- For rise times of 20 and 2 s for the average wind speed, the variations can be handled by the wind turbine.
- The large inertia in the rotor limits the demands on control speed of the turbine.
- The control of the DC grid for the wind farm is fast compared to the dynamics of the turbine.

Operation of the DC based wind farm

Operation during a sudden step in the wind speed from 5 m/s to 10 m/s

Behavior of the internal grid for the slow dynamics.

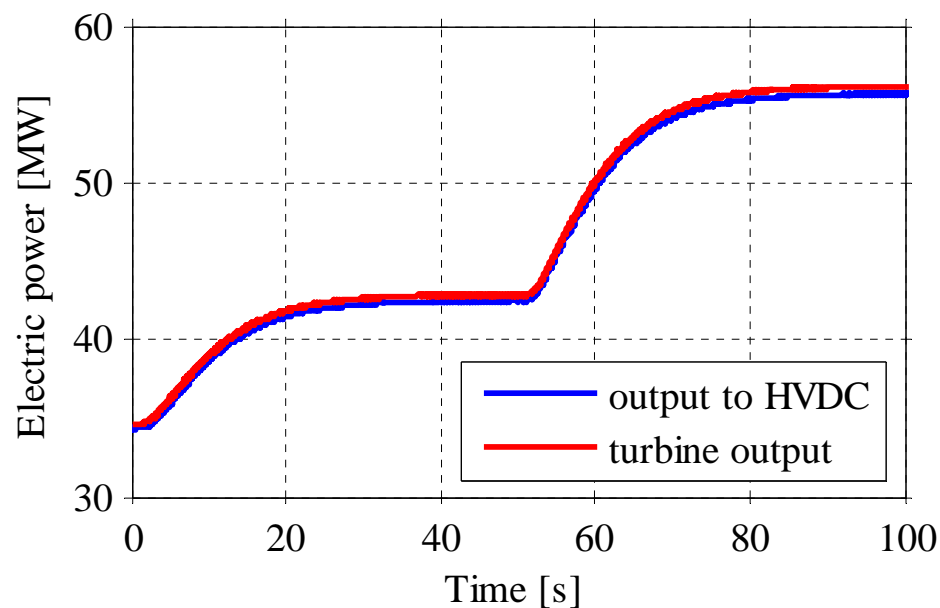
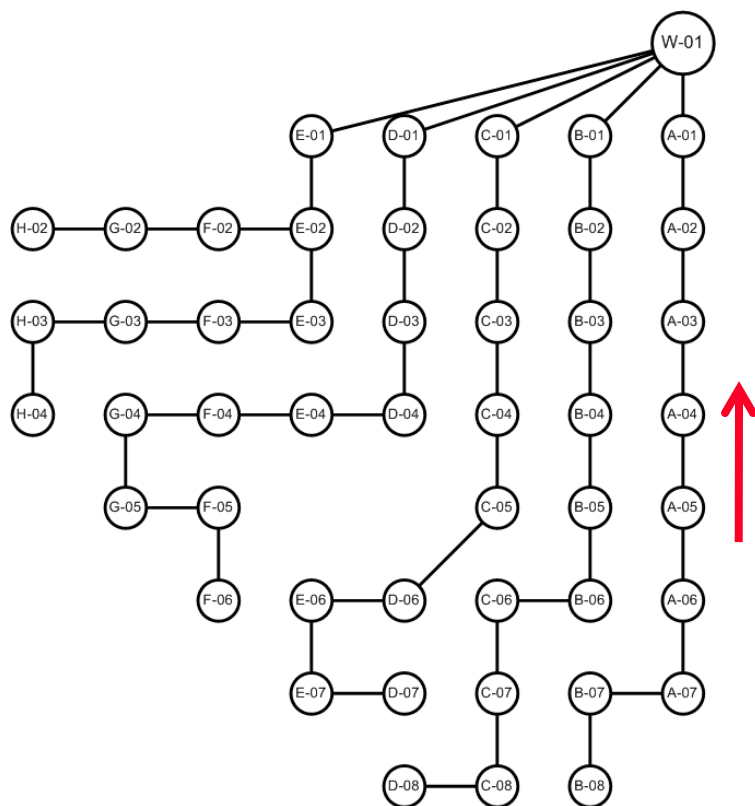

Operation of the DC based wind farm

Operation during a sudden step in the wind speed from 5 m/s to 10 m/s

Electrical output power for the slow dynamics.

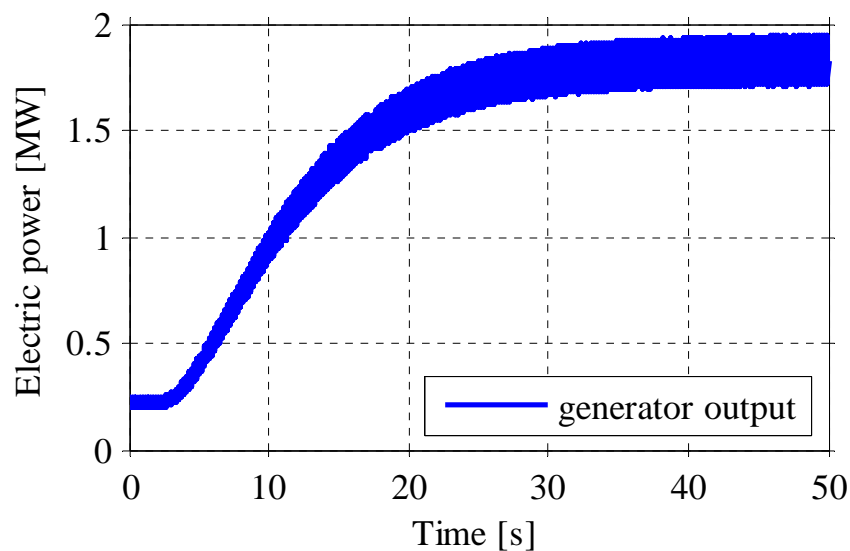

Electrical power from the generator

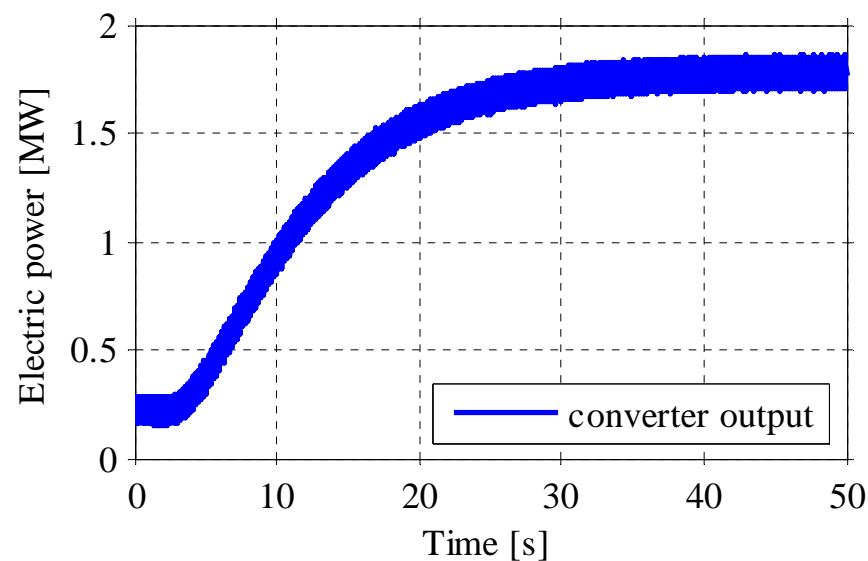

Electrical power from the wind turbine DC/DC converter