

# HAWC2 – overview. For IEA Annex 23 subtask 2 – phase 4

Torben J. Larsen, Anders M. Hansen  
March 13, 2009

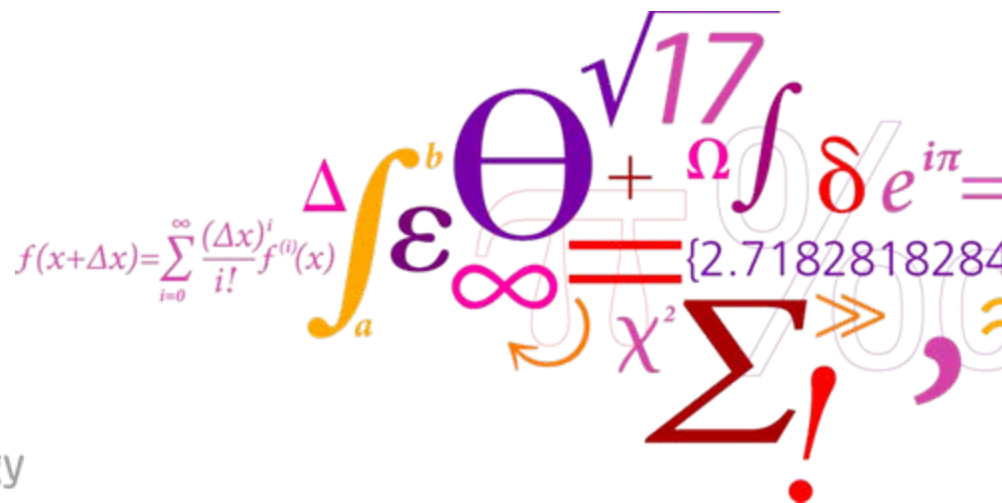

# Structural formulation

- Structural core based on a multibody formulation
- Joints modeled by geometric constraints
- Arbitrary geometry, but so far limited to Timoshenko beam elements

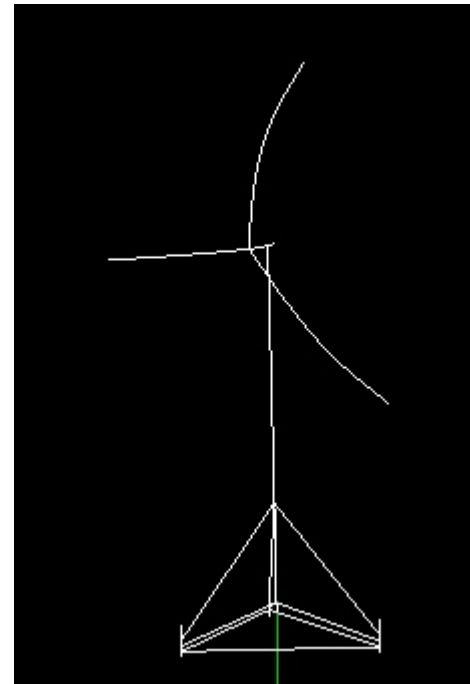
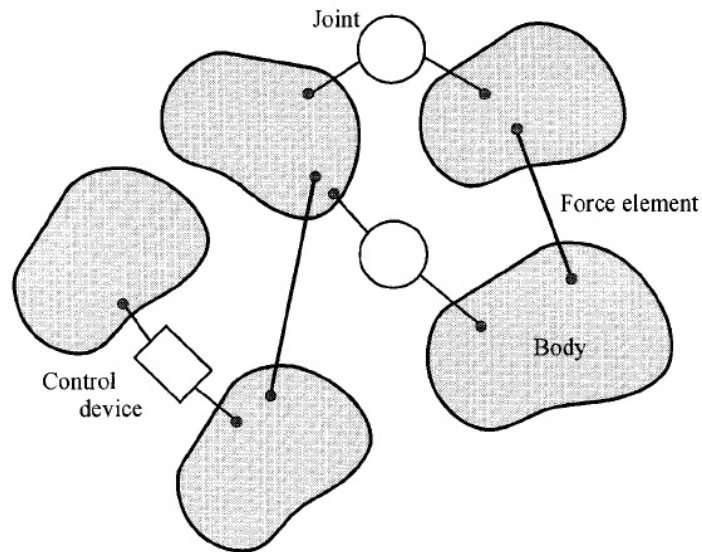

# Aerodynamics

- Aerodynamic model:
  - BEM model
    - Based on Glauert theory
    - Prandtl tip loss correction
  - Dynamic inflow:
    - Two first order filter approaches
    - Near wake model (new)
  - Dynamic stall models:
    - S.Ø. model
    - Beddoes model
    - Beddoes expanded for trailing edge flaps

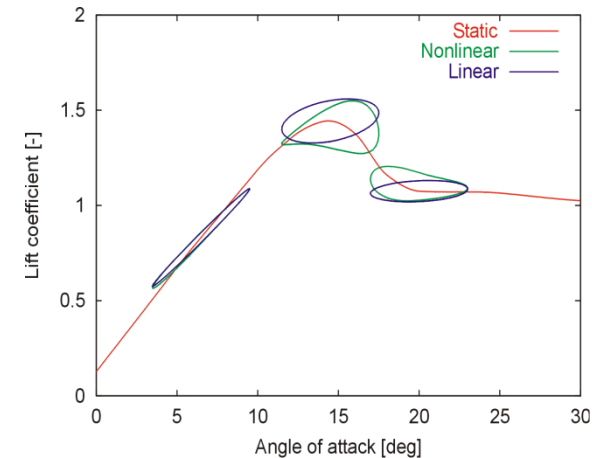
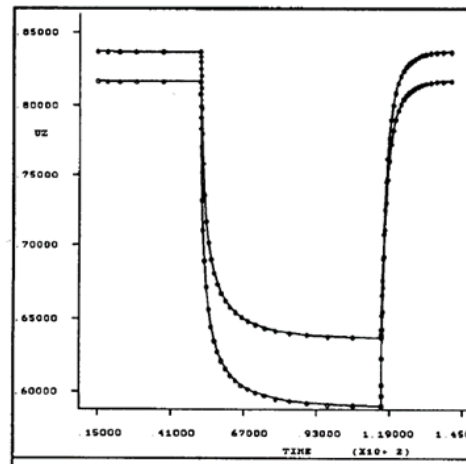
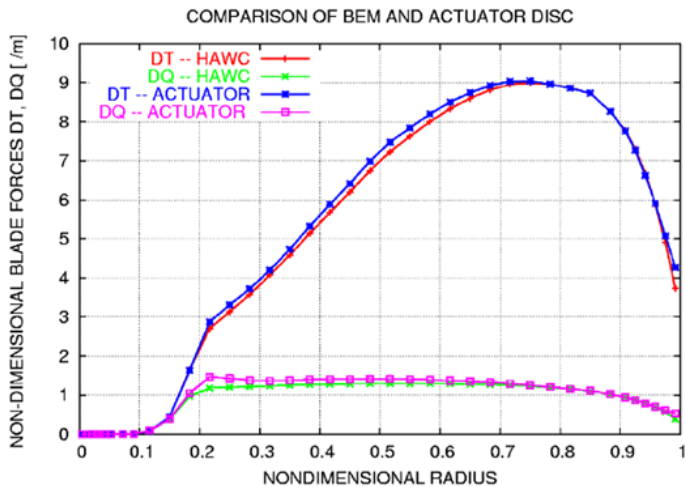
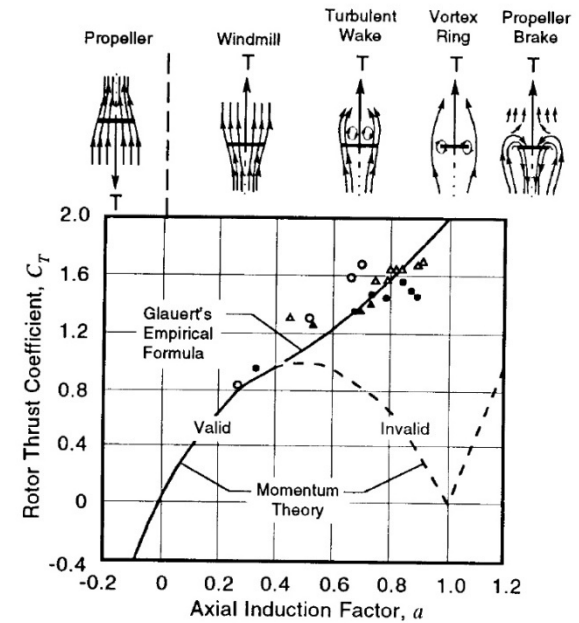

# Wind

- Deterministic wind:
  - Shears (log, power law, user defined)
  - Gusts (acc. to IEC 61400-1 ed. 3)
  - Tower shadow (potential flow, jet model)
- Stochastic wind:
  - Build-in Mann turbulence generator (Fully coherent 3D-turbulence)
  - Read module for FLEX turbulence
  - Dynamic wake meander model for turbines in wake

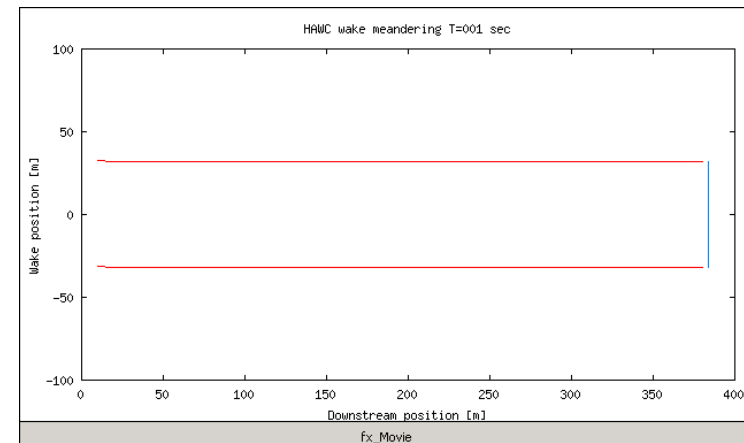
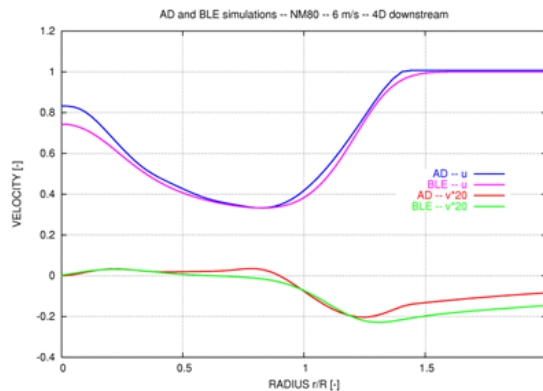
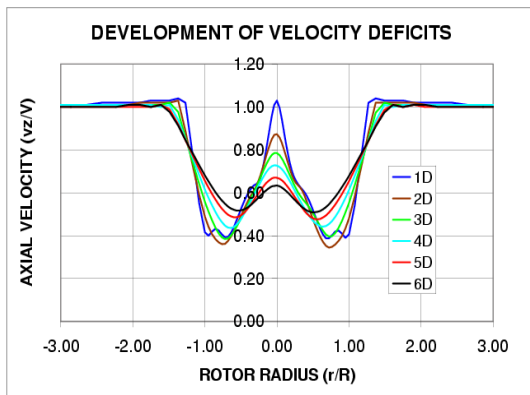
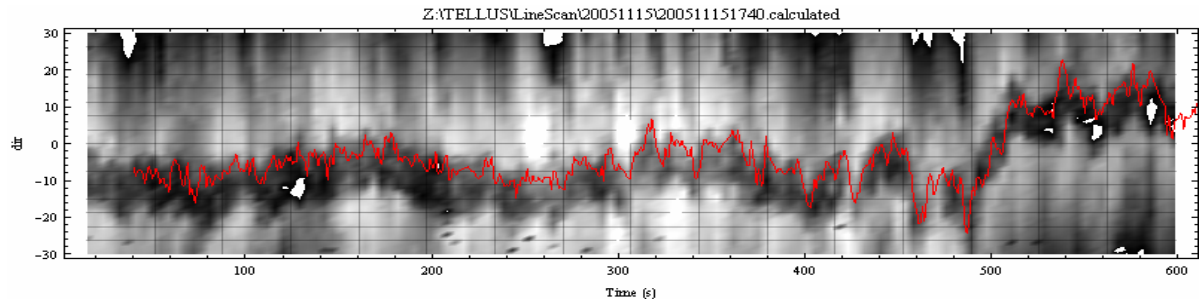
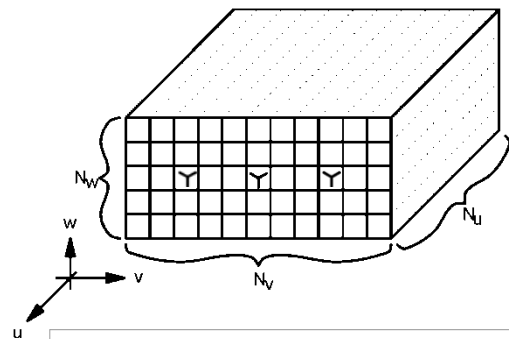
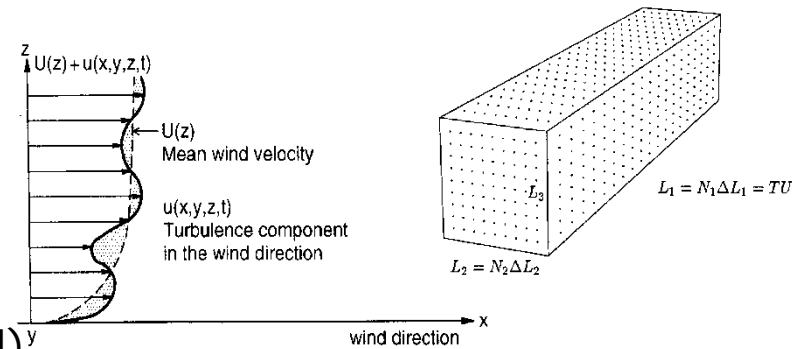

# Hydrodynamics

## Hydrodynamic kinematics:

- Regular and irregular Airy waves, directional spreading
- FFT feature to reproduce kinematics based on elevation
- Wheeler stretching used for shallow waters

## Hydrodynamic loads:

- Morison's formula (assumption of slender elements)
- Axial damping term in end nodes
- Axial dynamic pressure inserted as concentrated force on end nodes and distributed forces over conical sections

## Buoyancy loads from static pressure:

- Axial dynamic pressure inserted as concentrated force on end nodes and distributed forces over conical sections
- Distributed perpendicular force contribution on angled elements
- Restoring moments distribution on conical sections

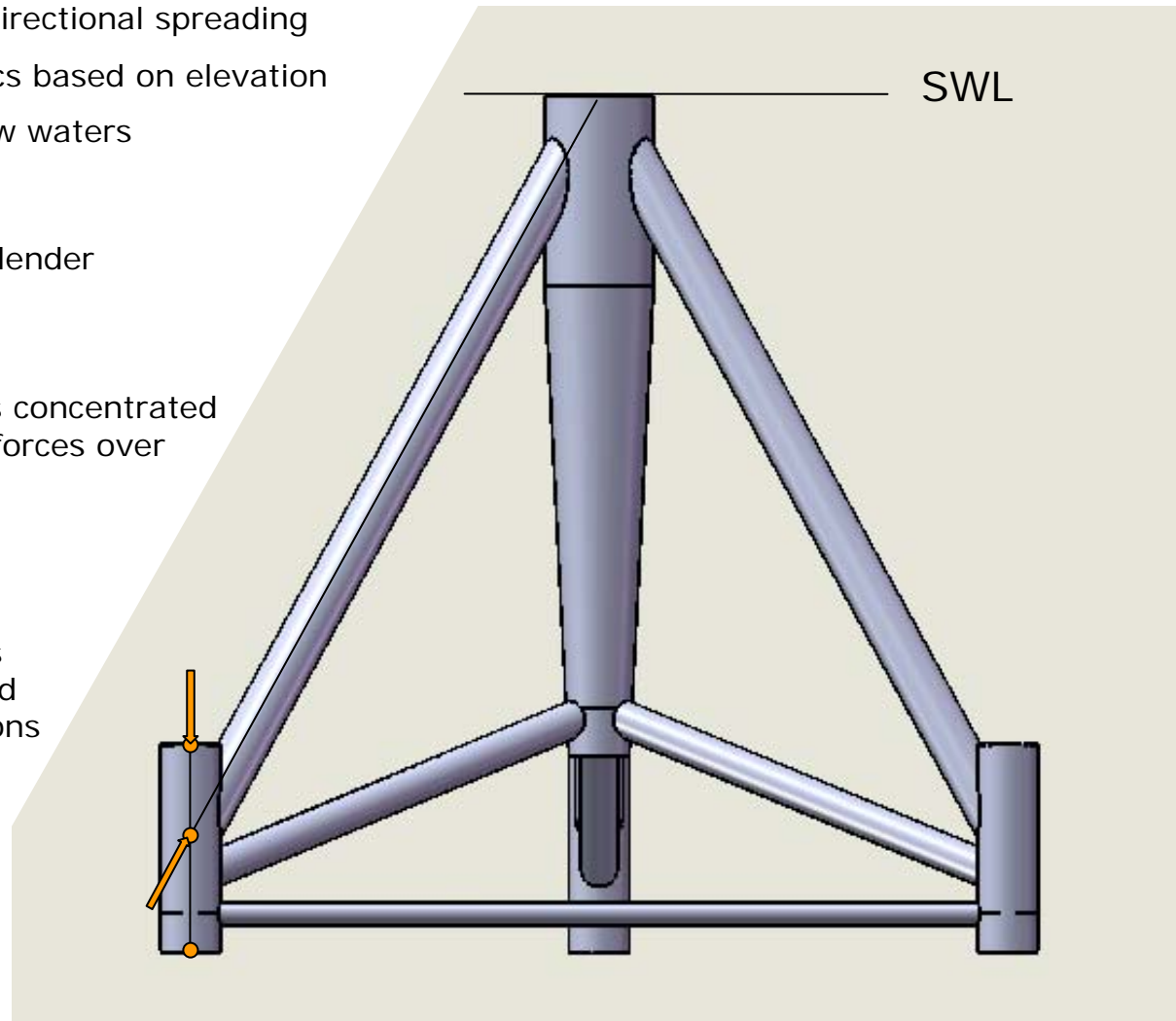

# Hydrodynamic loading

- Morisons formula, distributed load perpendicular to element

$$F = F_m + F_D$$

$$F_m = \rho V \dot{U} + \rho C_m V_R \dot{U}_{rel}$$

$$F_D = \frac{1}{2} \rho D C_D U_{rel} |U_{rel}|$$

- Buoyancy, distributed load contributions

$$\vec{F}_b = -g\rho \begin{Bmatrix} A_{3,1} S \\ A_{3,2} S \\ -\frac{\partial S}{\partial z} (z - z_0) + \frac{\partial S}{\partial z} p_{dyn} \end{Bmatrix} \quad \vec{M}_b = -g\rho \begin{Bmatrix} -A_{3,2} \frac{\partial r}{\partial z} \pi r^3 \\ A_{3,1} \frac{\partial r}{\partial z} \pi r^3 \\ 0 \end{Bmatrix}$$

- Buoyancy and drag contributions at end nodes

$$F_{b,end}(3) = \rho g S (z - z_0) + S p_{dyn} + \frac{1}{2} \rho C_{d,axial} S u_{rel} |u_{rel}|$$

# Mooring lines

- Single line characteristic calculated, e.g. using MIMOSA
- Line characteristics coupled in DLL taken number of lines, orientation, anchor/fairlead positions into account.
- Forces applied to structure in specific node.

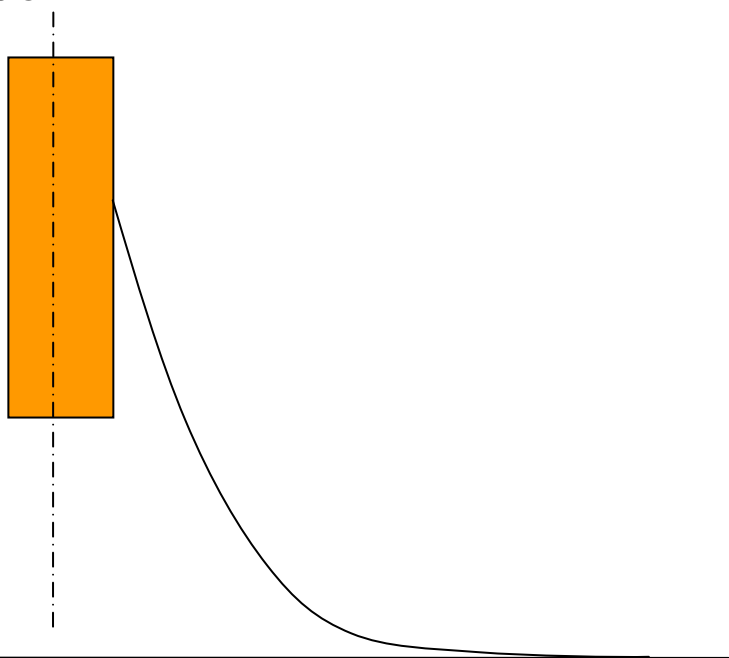

\* LINE CHARACTERISTICS OF LINE NUMBER: 1 \*

-----  
Line characteristics number: 1

DISTANCE (m)	TENSION (kN)	H. TENSION (kN)	SUSPL (m)	TEN. ANCH (kN)
654.26	174.7	0.2	250.3	0.0
672.50	178.5	4.0	255.7	0.0
702.05	190.0	15.5	271.3	0.0
730.16	209.2	34.7	295.5	0.0
753.94	236.0	61.5	326.4	0.0
773.34	270.4	96.0	362.3	0.0
789.03	312.6	138.2	401.9	0.0
801.80	362.4	188.0	444.1	0.0
812.31	419.8	245.4	488.3	0.0
821.08	484.9	310.6	534.0	53.2
828.48	557.7	383.4	580.8	158.6
834.79	638.1	463.8	628.6	272.3
840.24	726.2	552.0	677.1	394.1
845.00	822.0	647.8	726.1	523.9
849.20	925.4	751.2	775.7	661.7
852.93	1036.4	862.3	825.6	807.5
856.28	1155.2	981.1	875.8	961.0
859.27	1281.5	1107.5	905.0	1107.6
861.67	1415.6	1240.6	905.3	1241.7
863.61	1557.3	1380.4	905.6	1383.4
865.20	1706.7	1527.2	906.0	1532.9
866.56	1863.7	1680.9	906.4	1690.0
867.73	2028.4	1841.6	906.8	1854.7
868.77	2200.7	2009.4	907.2	2027.2
869.71	2380.7	2184.4	907.6	2207.2
870.58	2568.4	2366.5	908.0	2395.0
871.40	2763.7	2555.9	908.5	2590.4
872.17	2966.7	2752.4	909.0	2793.5
872.92	3177.4	2956.3	909.5	3004.2
873.66	3395.7	3167.4	910.0	3222.6
874.38	3621.6	3385.8	910.5	3448.7
875.09	3855.2	3611.5	911.1	3682.4
875.81	4096.5	3844.5	911.7	3923.8
876.52	4345.5	4084.9	912.2	4172.9
877.24	4602.1	4332.6	912.9	4429.6
877.97	4866.3	4587.7	913.5	4694.0
878.71	5138.3	4850.1	914.1	4966.0
879.45	5417.9	5119.9	914.8	5245.7
880.21	5705.1	5397.0	915.5	5533.1
880.98	6000.0	5681.6	916.2	5828.1

# Natural frequencies

- Boyancy, hydrodynamic forces, mooring line forces and extra added forces in that matter is linearized and included as stiffness, damping contributions in the node where mooring line forces are attached.

Full System Eigenmode	Natural Frequency (Hz)
Platform Surge	0.0077
Platform Sway	0.0077
Platform Heave	0.033
Platform Roll	0.065
Platform Pitch	0.065
Platform Yaw	0.118
1st Tower Fore-Aft	0.47
1st Tower Side-to-Side	0.48
1st Drivetrain Torsion	0.64
1st Blade Collective Flap	0.71
1st Blade Asymmetric Flapwise Pitch	0.67
1st Blade Asymmetric Flapwise Yaw	0.66
1st Blade Asymmetric Edgewise Pitch	1.076
1st Blade Asymmetric Edgewise Yaw	1.095
2nd Tower Fore-Aft	
2nd Tower Side-to-Side	
2nd Blade Collective Flap	1.961
2nd Blade Asymmetric Flapwise Pitch	1.859
2nd Blade Asymmetric Flapwise Yaw	1.711

Regarding static results:  
Heave of 0.95 m upwards